

SULIT



LEMBAGA PEPERIKSAAN
KEMENTERIAN PENDIDIKAN MALAYSIA

SIJIL PELAJARAN MALAYSIA 2019

BIOLOGY

Kertas 1

Okt./Nov.

1 $\frac{1}{4}$ jam

4551/1

Satu jam lima belas minit

JANGAN BUKA KERTAS PEPERIKSAAN INI SEHINGGA DIBERITAHU

1. *Kertas peperiksaan ini adalah dalam dwibahasa.*
2. *Soalan dalam bahasa Inggeris mendahului soalan yang sepadan dalam bahasa Melayu.*
3. *Calon dikehendaki membaca maklumat di halaman belakang kertas peperiksaan ini.*

Kertas peperiksaan ini mengandungi 48 halaman bercetak.

[Lihat halaman sebelah

4551/1 © 2019 Hak Cipta Kerajaan Malaysia

SULIT



1 Diagram 1 shows a structure in one of the systems in a human body.

Rajah 1 menunjukkan suatu struktur dalam satu daripada sistem dalam badan manusia.

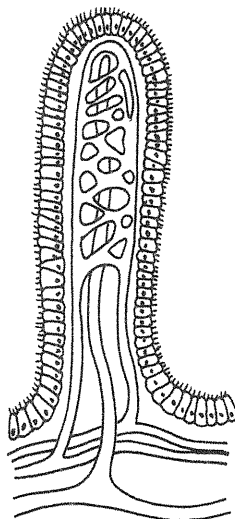

Diagram 1

Rajah 1

What is the system?

Apakah sistem itu?

- A Digestive
Pencernaan
- B Lymphatic
Limfa
- C Blood circulatory
Peredaran darah
- D Respiratory
Respirasi

2 Diagram 2 shows a *Paramecium* sp. that lives in freshwater.

Rajah 2 menunjukkan *Paramecium* sp. yang hidup di air tawar.

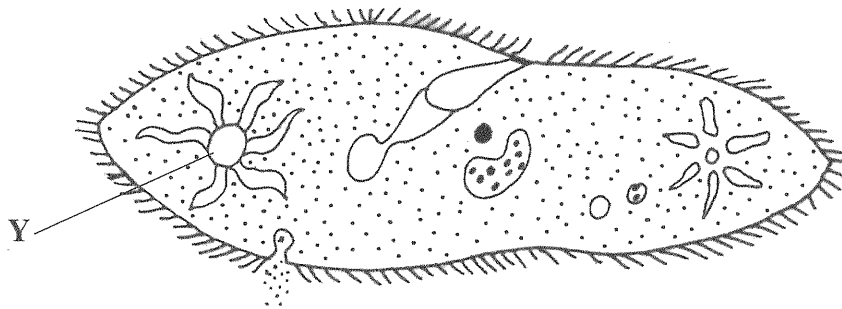

Diagram 2

Rajah 2

What will happen to the *Paramecium* sp. if structure Y does not function?

Apakah yang akan berlaku kepada *Paramecium* sp. itu jika struktur Y tidak berfungsi?

- A Burst
Meletus
- B Expand
Mengembang
- C Shrink
Mengecut
- D Maintain its shape
Mengekalkan bentuknya

- 3 Diagram 3 shows a bar chart of the density of organelle X in two types of cells.

Rajah 3 menunjukkan satu carta palang bagi kepadatan organel X dalam dua jenis sel.

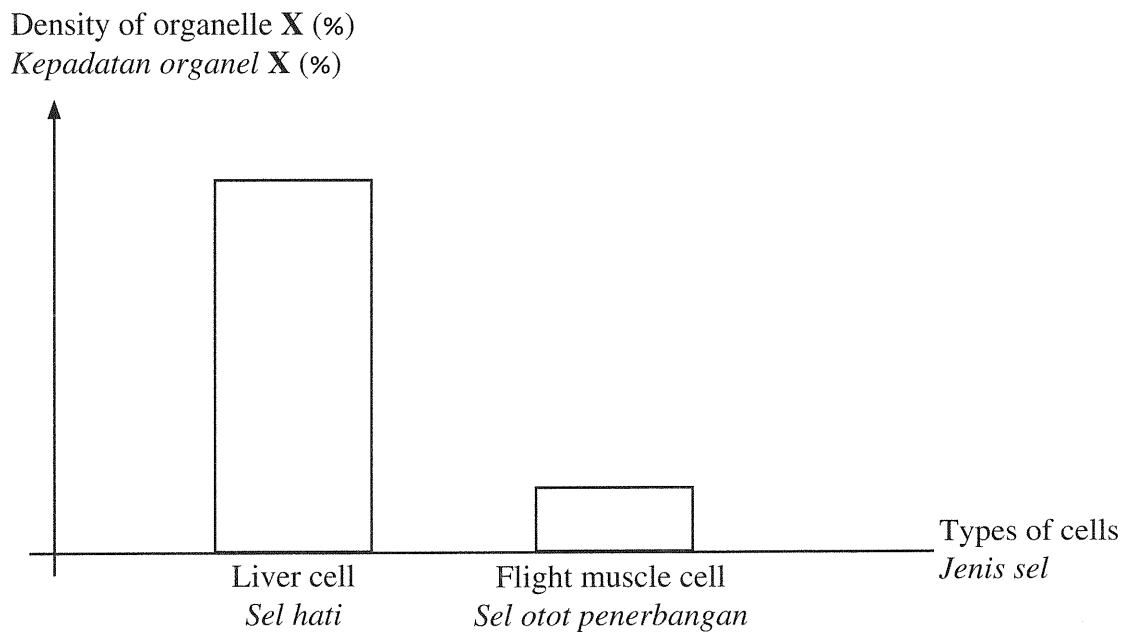

Diagram 3

Rajah 3

What is the function of organelle X?

Apakah fungsi organel X?

- A Produces spindle fibres
Menghasilkan gentian gelendong
- B Transports synthesised enzymes
Mengangkut enzim yang telah disintesis
- C Produces energy in the form of ATP
Menghasilkan tenaga dalam bentuk ATP
- D Secretes mucus to protect the mucous membranes
Merembeskan mukus untuk melindungi membran mukus

- 4 Diagram 4 shows the movement of substances across the plasma membrane.
Rajah 4 menunjukkan pergerakan bahan merentas membran plasma.

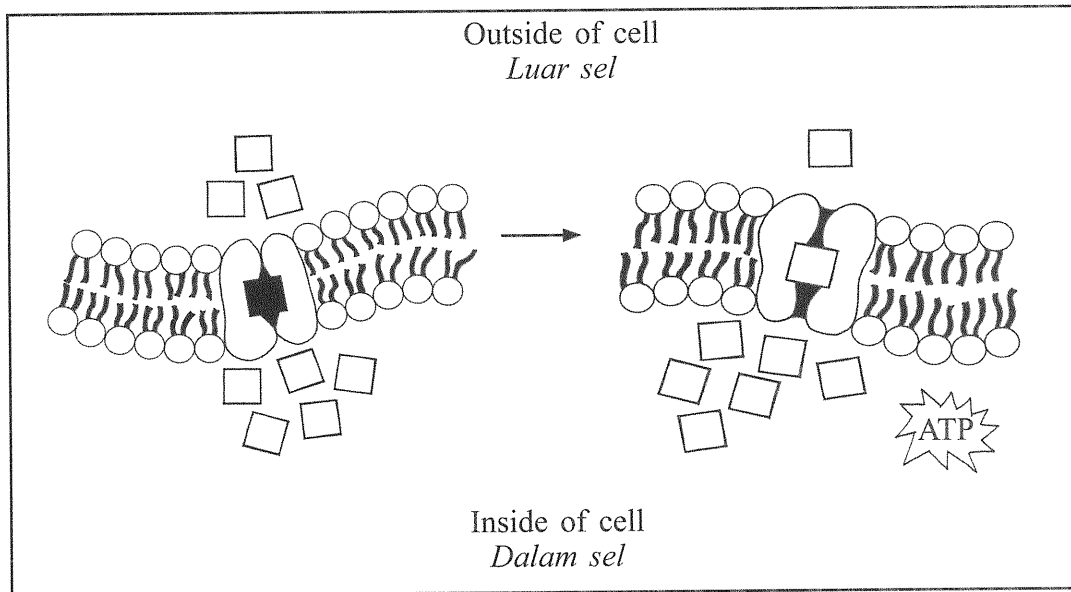

Diagram 4

Rajah 4

Which of the following statements explains the movement of substances in Diagram 4?
Antara pernyataan berikut, yang manakah menerangkan pergerakan bahan dalam Rajah 4?

- A** Movement of substances going down the concentration gradient with the help of pore protein
Pergerakan bahan menuruni kecerunan kepekatan dengan bantuan protein liang
- B** Movement of substances against the concentration gradient with the help of pore protein
Pergerakan bahan menentang kecerunan kepekatan dengan bantuan protein liang
- C** Movement of substances from the region of low concentration to the region of high concentration with the help of carrier protein
Pergerakan bahan dari kawasan berkepekatan rendah ke kawasan berkepekatan tinggi dengan bantuan protein pembawa
- D** Movement of substances from the region of high concentration to the region of low concentration with the help of carrier protein
Pergerakan bahan dari kawasan berkepekatan tinggi ke kawasan berkepekatan rendah dengan bantuan protein pembawa

[Lihat halaman sebelah

SULIT

5 Diagram 5 shows clothes hung on the clothes line.

Rajah 5 menunjukkan pakaian yang disidai di ampaian.

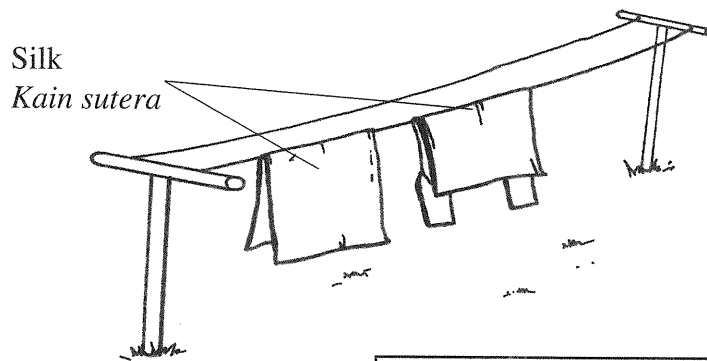

Surrounding temperature : 45°C
Suhu persekitaran

Relative humidity : Very low
Kelembapan relatif udara Sangat rendah

Diagram 5

Rajah 5

What will happen to the clothes after 5 hours?

Apakah yang akan berlaku pada pakaian itu selepas 5 jam?

A Crumpled

Berkedut

B Colour faded

Warna pudar

C Shinier

Lebih berkilat

D No change

Tiada perubahan

6 Diagram 6 shows a type of human blood cell.
Rajah 6 menunjukkan sejenis sel darah manusia.

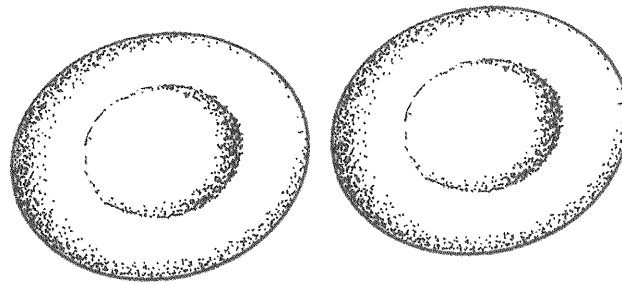
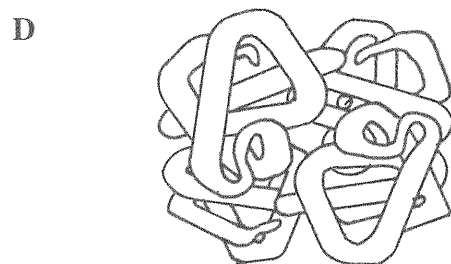
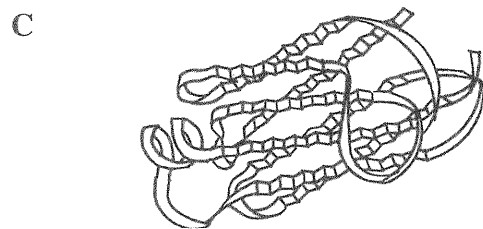
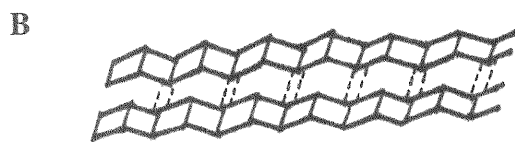

Diagram 6
Rajah 6

Which of the following protein structures can be found in the blood cell?
Antara struktur protein berikut, yang manakah boleh dijumpai dalam sel darah itu?



[Lihat halaman sebelah
SULIT

- 7 Diagram 7 shows an experiment to study the reaction of an enzyme at the temperature of 37°C.

Rajah 7 menunjukkan suatu eksperimen untuk mengkaji tindak balas enzim pada suhu 37°C.

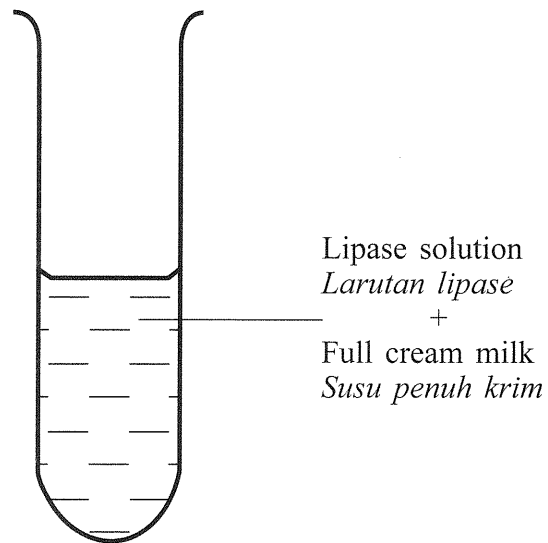

Diagram 7

Rajah 7

What are the results after 15 minutes?

Apakah keputusan selepas 15 minit?

	Product <i>Hasil tindak balas</i>	pH
A	Amino acids <i>Asid amino</i>	Increases <i>Meningkat</i>
B	Amino acids <i>Asid amino</i>	Decreases <i>Menurun</i>
C	Fatty acids <i>Asid lemak</i>	Decreases <i>Menurun</i>
D	Fatty acids <i>Asid lemak</i>	Increases <i>Meningkat</i>

8 Diagram 8 shows a process that occurs in human digestive system.

Rajah 8 menunjukkan satu proses yang berlaku dalam sistem pencernaan manusia.

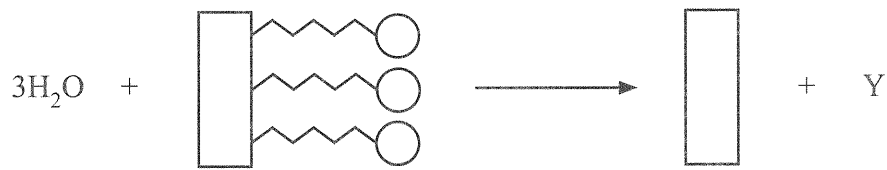

Diagram 8

Rajah 8

Which of the following is Y?

Antara yang berikut, yang manakah Y?

A Triglyceride

Trigliserida

B Fatty acids

Asid lemak

C Glycerol

Gliserol

D Lipids

Lipid

[Lihat halaman sebelah

SULIT

9 Diagram 9 shows **R** phase in cell division.

*Rajah 9 menunjukkan fasa **R** dalam pembahagian sel.*

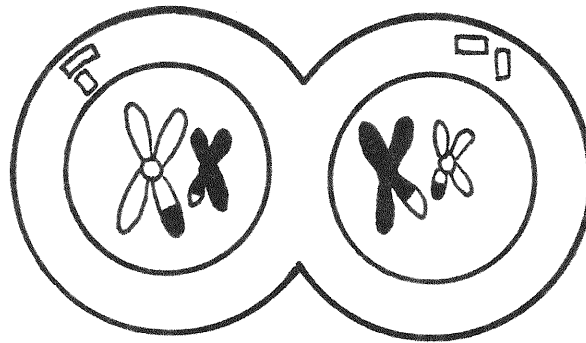

R phase
*Fasa **R***

Diagram 9

Rajah 9

What is the next phase after **R** phase?

*Apakah fasa seterusnya selepas fasa **R**?*

- A Anaphase I
Anafasa I
- B Telophase I
Telofasa I
- C Prophase II
Profasa II
- D Telophase II
Telofasa II

10 Which of the following diagrams of cell division is matched correctly with its phase?

Antara rajah pembahagian sel berikut, yang manakah padanan betul dengan fasanya?

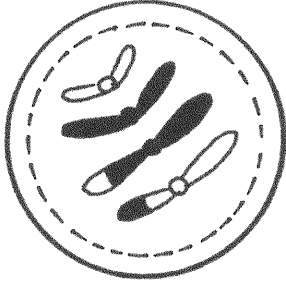
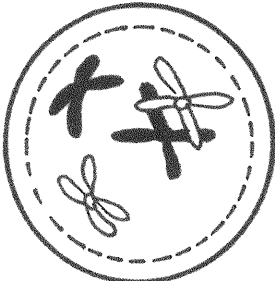
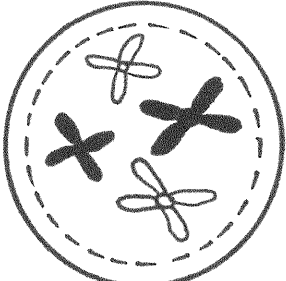
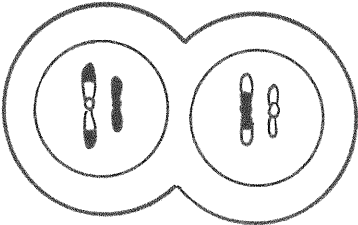
	Cell division <i>Pembahagian sel</i>	Phase <i>Fasa</i>
A		Prophase II <i>Profasa II</i>
B		Prophase I <i>Profasa I</i>
C		Metaphase I <i>Metafasa I</i>
D		Telophase I <i>Telofasa I</i>

[Lihat halaman sebelah
SULIT

11 The following are explanations on the cell cycle by two Biology students.

Berikut adalah penerangan tentang kitar sel oleh dua orang murid Biologi.

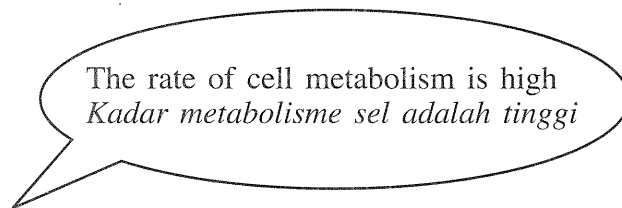
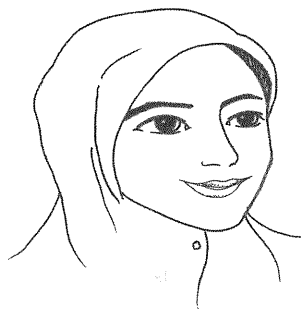
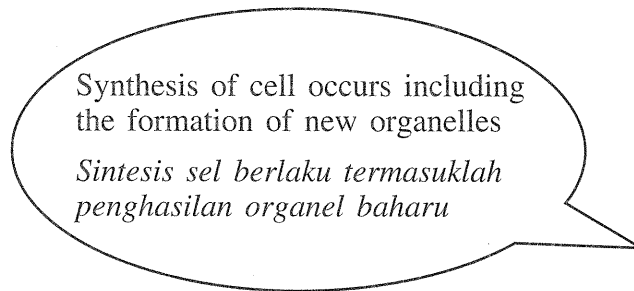

What is the phase explained by the students?

Apakah fasa yang diterangkan oleh murid tersebut?

- A G_1
 - B S
 - C G_2
 - D M phase
- Fasa M*

12 The statement below refers to a technique in agriculture.

Pernyataan di bawah merujuk kepada satu teknik dalam pertanian.

Explant is cultured in sterile culture medium. Callus is formed and developed into plantlets.

Eksplan dikultur dalam medium kultur yang steril. Kalus terbentuk dan berkembang menjadi anak-anak pokok.

What is the technique?

Apakah teknik tersebut?

A Selective breeding

Pembiakbakaan

B Genetic engineering

Kejuruteraan genetik

C Hydroponics

Hidroponik

D Cloning

Pengklonan

13 Incomplete digestion of food could happen in humans if

Pencernaan makanan yang tidak lengkap boleh berlaku dalam manusia sekiranya

A the body temperature is 40°C.

suhu badan 40°C.

B the concentration of digestive enzymes is high.

kepekatan enzim pencernaan tinggi.

C thyroxine hormones are increased.

hormon tiroksina meningkat.

D pH level is very low in the stomach.

nilai pH yang sangat rendah dalam perut.

[Lihat halaman sebelah

SULIT

14 Diagram 10 shows organisms P, Q and R.

Rajah 10 menunjukkan organisma P, Q dan R.

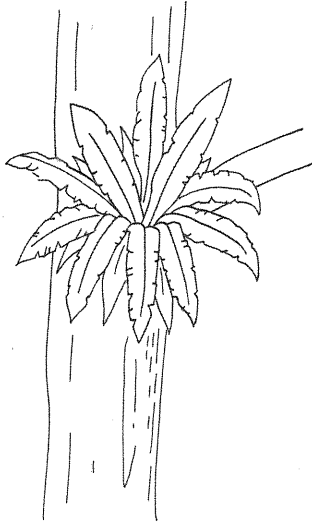

Organism P
Organisma P

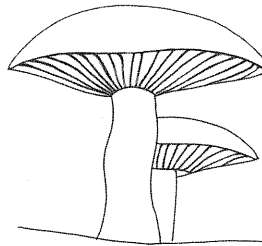

Organism Q
Organisma Q

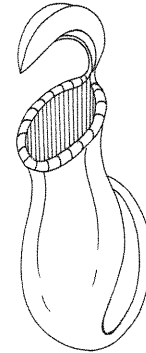

Organism R
Organisma R

Diagram 10

Rajah 10

Classify the organisms according to the types of nutrition.

Kelaskan organisma tersebut mengikut jenis nutrisi.

		Organism <i>Organisma</i>		
		P	Q	R
A	Chemoautotroph <i>Kemoautotrof</i>	Saprophytism <i>Saprofitisme</i>	Parasitism <i>Parasitisme</i>	
B	Chemoautotroph <i>Kemoautotrof</i>	Holozoic <i>Holozoik</i>	Parasitism <i>Parasitisme</i>	
C	Photoautotroph <i>Fotoautotrof</i>	Parasitism <i>Parasitisme</i>	Saprophytism <i>Saprofitisme</i>	
D	Photoautotroph <i>Fotoautotrof</i>	Saprophytism <i>Saprofitisme</i>	Holozoic <i>Holozoik</i>	

- 15 Table 1 shows the results obtained in an experiment to determine the energy value in a groundnut.

Jadual 1 menunjukkan keputusan yang diperolehi dalam eksperimen untuk menentukan nilai tenaga dalam kacang tanah.

Mass of groundnut (g) <i>Jisim kacang tanah (g)</i>	0.7
Volume of heated water (ml) <i>Isi padu air yang dipanaskan (ml)</i>	15
Increase of water temperature (°C) <i>Peningkatan suhu air (°C)</i>	55

Table 1

Jadual 1

Calculate the energy value in the groundnut.

[Specific heat capacity of water = $4.2 \text{ J g}^{-1} \text{ }^\circ\text{C}^{-1}$]

Hitungkan nilai tenaga dalam kacang tanah tersebut.

[*Muatan haba tentu air = $4.2 \text{ J g}^{-1} \text{ }^\circ\text{C}^{-1}$*]

- A 2.426 kJ g⁻¹
- B 4.95 kJ g⁻¹
- C 2426 kJ g⁻¹
- D 4950 kJ g⁻¹

[Lihat halaman sebelah
SULIT

16 The chemical equation below shows a part of reaction in a photosynthesis.

Persamaan kimia di bawah menunjukkan sebahagian daripada tindak balas dalam fotosintesis.



What will happen to hydroxyl ion when it loses electrons?

Apakah yang akan berlaku kepada ion hidroksil apabila kehilangan elektron?

- I Produces glucose
Menghasilkan glukosa
 - II Produces energy
Menghasilkan tenaga
 - III Produces oxygen
Menghasilkan oksigen
 - IV Produces hydroxyl group
Menghasilkan kumpulan hidroksil
- A I and II
I dan II
 - B I and III
I dan III
 - C II and IV
II dan IV
 - D III and IV
III dan IV

17 Diagram 11 shows two methods to overcome obesity.

Rajah 11 menunjukkan dua kaedah untuk mengatasi obesiti.

Methods <i>Kaedah</i>	Similarity <i>Persamaan</i>	Differences <i>Perbezaan</i>
X diet <i>Diet X</i>	Body weight loss <i>Penurunan berat badan</i>	Low intake of carbohydrates <i>Pengambilan karbohidrat yang rendah</i>
Y surgery <i>Pembedahan Y</i>		Reduce intestinal length <i>Mengurangkan panjang usus</i>

Diagram 11

Rajah 11

Which of the following health problems are caused by these methods?

Antara masalah kesihatan berikut, yang manakah disebabkan oleh kaedah tersebut?

	X diet <i>Diet X</i>	Y surgery <i>Pembedahan Y</i>
A	Incomplete digestion <i>Pencernaan tidak lengkap</i>	Constipation <i>Sembelit</i>
B	Diabetes insipidus <i>Diabetes insipidus</i>	Diabetes mellitus <i>Diabetes melitus</i>
C	Hyperglycemia <i>Hiperglisemia</i>	Loss of appetite <i>Hilang selera makan</i>
D	Hypoglycemia <i>Hipoglisemia</i>	Deficiency of nutrients <i>Kekurangan nutrien</i>

[Lihat halaman sebelah
SULIT

18 Diagram 12 shows an organelle in a plant cell.

Rajah 12 menunjukkan satu organel dalam sel tumbuhan.

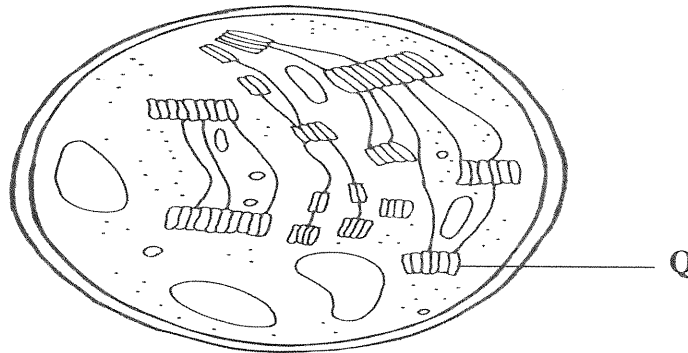

Diagram 12

Rajah 12

What is the effect of the damage on structure **Q** towards the function of the organelle?

*Apakah kesan kerosakan struktur **Q** terhadap fungsi organel tersebut?*

A The concentration of carbon dioxide gas increases

Kepekatan gas karbon dioksida meningkat

B More hydrogen ions are produced

Lebih banyak ion hidrogen dihasilkan

C More water molecules are produced

Lebih banyak molekul air dihasilkan

D No changes occur in the end product

Tiada perubahan berlaku pada produk akhir

19 Diagram 13 shows a type of organism.

Rajah 13 menunjukkan sejenis organisma.

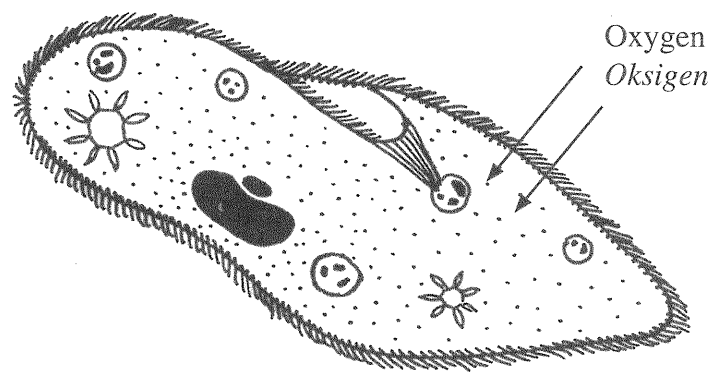

Diagram 13

Rajah 13

How does the organism receive sufficient oxygen supply despite not having a respiratory system?

Bagaimanakah organisma tersebut menerima bekalan oksigen yang mencukupi walaupun tidak mempunyai sistem respirasi?

- A Has a small ratio of total surface area per volume
Mempunyai nisbah jumlah luas permukaan per isi padu yang kecil
- B Has a large ratio of total surface area per volume
Mempunyai nisbah jumlah luas permukaan per isi padu yang besar
- C The freshwater contains high concentration of dissolved oxygen
Air tawar mengandungi kepekatan oksigen terlarut yang tinggi
- D Has ciliated plasma membrane that increases the size of the organism
Mempunyai membran plasma yang bersilia yang meningkatkan saiz organisma

20 Which equation shows oxygen debt?

Persamaan manakah yang menunjukkan hutang oksigen?

- A Glucose + oxygen \longrightarrow carbon dioxide + water + energy
Glukosa + oksigen \longrightarrow karbon dioksida + air + tenaga
- B Lactic acid + oxygen \longrightarrow carbon dioxide + water + energy
Asid laktik + oksigen \longrightarrow karbon dioksida + air + tenaga
- C Glucose \longrightarrow ethanol + carbon dioxide + energy
Glukosa \longrightarrow etanol + karbon dioksida + tenaga
- D Glucose \longrightarrow lactic acid + energy
Glukosa \longrightarrow asid laktik + tenaga

21 Diagram 14 shows a respiratory system of an aquatic organism.

Rajah 14 menunjukkan sistem respirasi satu organisma akuatik.

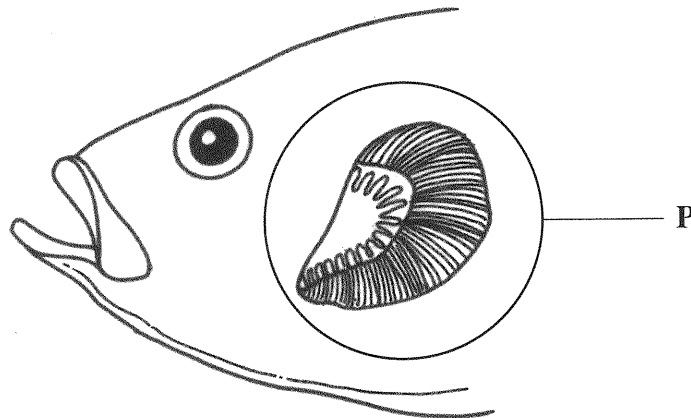

Diagram 14

Rajah 14

What is the adaptation of structure **P** for an optimal gaseous exchange?

*Apakah penyesuaian struktur **P** bagi pertukaran gas yang optimum?*

- A Has a bony gill arch
Mempunyai lengkung insang yang bertulang
- B Filament surface which is layered and thick
Permukaan filamen yang berlapis-lapis dan tebal
- C Rich supply of blood capillaries
Kaya dengan jaringan kapilari darah
- D Has a line of gills
Mempunyai sebaris sisir insang

22 Diagram 15 shows a part of the turtle's respiratory structure.

Rajah 15 menunjukkan sebahagian struktur respirasi seekor penyu.

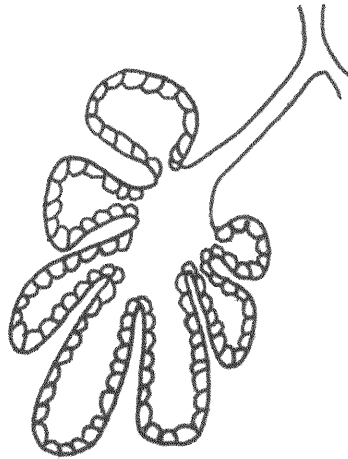

Diagram 15

Rajah 15

What is the characteristic of the turtle's respiratory structure for survival in its habitat?

Apakah ciri struktur respirasi penyu untuk kemandirian dalam habitatnya?

A Narrow respiratory tract

Salur respirasi yang sempit

B Has a greater surface area

Mempunyai luas permukaan yang besar

C Has a counter-current mechanism

Mempunyai mekanisme tukar ganti lawan-arus

D Arrangement of epithelial cells in layers

Susunan sel epitelium yang berlapis

[Lihat halaman sebelah

SULIT

23 A skydiver is at a height of 3 248 metres above sea level and is ready for skydiving.

Which of the following conditions will be faced by the skydiver?

Seorang penerjun udara berada pada ketinggian 3248 meter dari aras laut dan bersedia untuk melakukan terjunan udara.

Antara keadaan berikut, yang manakah akan dialami oleh penerjun udara itu?

A Intercostal muscles and diaphragm muscles contract slowly

Otot interkosta dan otot diafragma mengecut dengan lebih perlahan

B More oxygen is inhaled to restore oxygen to its normal level

Lebih banyak oksigen disedut bagi mengembalikan oksigen ke paras normal

C Peripheral chemoreceptor is less stimulated to send the impulses to the medulla oblongata

Kemoreseptor periferi kurang dirangsang untuk menghantar impuls ke medula oblongata

D Less carbon dioxide is combined with haemoglobin to form carbaminohaemoglobin

Kurang karbon dioksida bergabung dengan hemoglobin untuk membentuk karbaminohemoglobin

24 Diagram 16 shows a pyramid of a food chain.

Rajah 16 menunjukkan satu piramid rantai makanan.

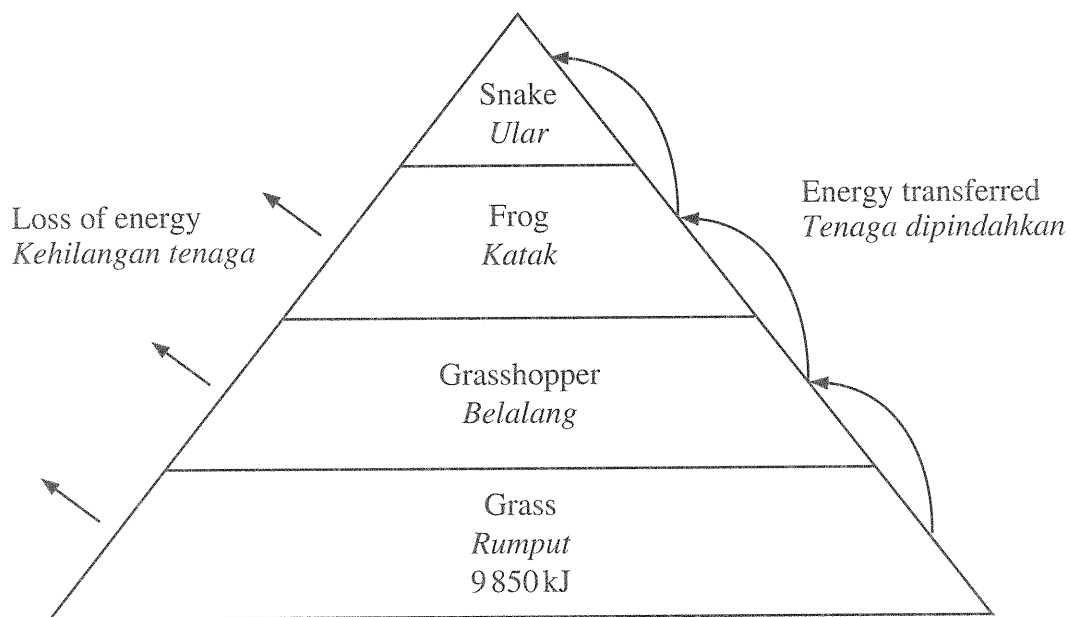

Diagram 16

Rajah 16

How much is the total energy received by the frog?

Berapakah jumlah tenaga yang diterima oleh katak?

- A 98.5 kJ
- B 246.5 kJ
- C 985 kJ
- D 4925 kJ

[Lihat halaman sebelah
SULIT

25 Diagram 17 shows an interaction between two organisms.

Rajah 17 menunjukkan suatu interaksi antara dua organisma.



Diagram 17

Rajah 17

What is the type of the interaction?

Apakah jenis interaksi itu?

A Mutualism

Mutualisme

B Parasitism

Parasitisme

C Saprophytism

Saprofitisme

D Commensalism

Komensalisme

- 26 A group of researchers conducted a research to estimate the size of leatherback sea turtle population that comes ashore on Rantau Abang Beach, Terengganu.

Sekumpulan penyelidik telah menjalankan satu kajian untuk menganggar saiz populasi penyu belimbing yang mendarat di Pantai Rantau Abang, Terengganu.

The data below are the findings of the research.

Data di bawah merupakan dapatan kajian itu.

Year <i>Tahun</i>	Number of turtles marked in the first catch <i>Bilangan penyu yang ditanda dalam tangkapan pertama</i>	Number of turtles in the second catch <i>Bilangan penyu dalam tangkapan kedua</i>	Number of marked turtles in the second catch <i>Bilangan penyu yang bertanda dalam tangkapan kedua</i>
1985	15	10	3
2015	5	3	1

What conclusion can be made from the data shown?

Apakah kesimpulan yang boleh dibuat daripada data yang ditunjukkan?

- A The turtle population in the year 1985 is almost four times more than the turtle population in the year 2015

Populasi penyu pada tahun 1985 ialah hampir empat kali ganda lebih banyak berbanding populasi penyu pada tahun 2015

- B The total amount of turtles caught in the second catch is 17 for both years

Jumlah bilangan penyu yang ditangkap pada tangkapan kedua ialah 17 ekor untuk dua tahun tersebut

- C The turtle population decreases by twice from year 1985 to 2015

Populasi penyu berkurangan sebanyak dua kali ganda dari tahun 1985 hingga 2015

- D The total amount of turtles alive in the year 2015 is 4

Jumlah bilangan penyu yang hidup pada tahun 2015 ialah 4 ekor

[Lihat halaman sebelah

SULIT

27 Diagram 18 shows a graph of the effect of sewage pollution along a river.

Rajah 18 menunjukkan graf kesan pencemaran sisa kumbahan di sepanjang sebatang sungai.

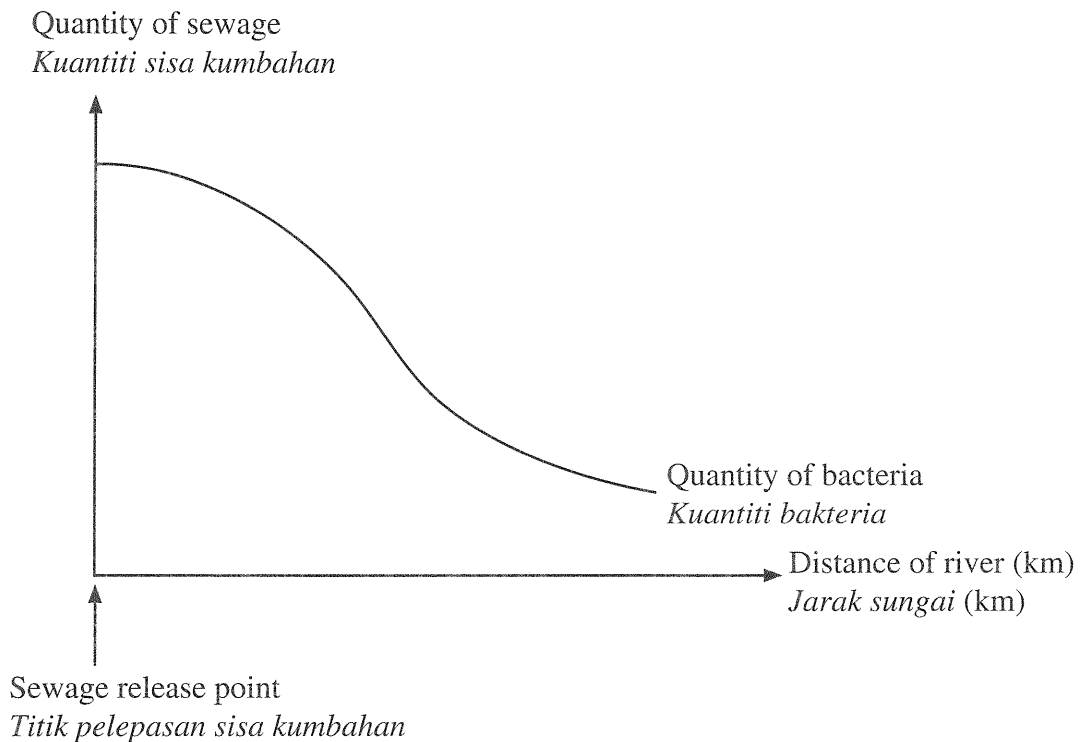

Diagram 18

Rajah 18

Which of the following graphs, shows the matching of the biochemical oxygen demand (BOD) level?

Antara graf berikut, yang manakah menunjukkan aras keperluan oksigen biokimia (BOD) yang sepadan?

A Quantity of sewage
Kuantiti sisa kumbahan

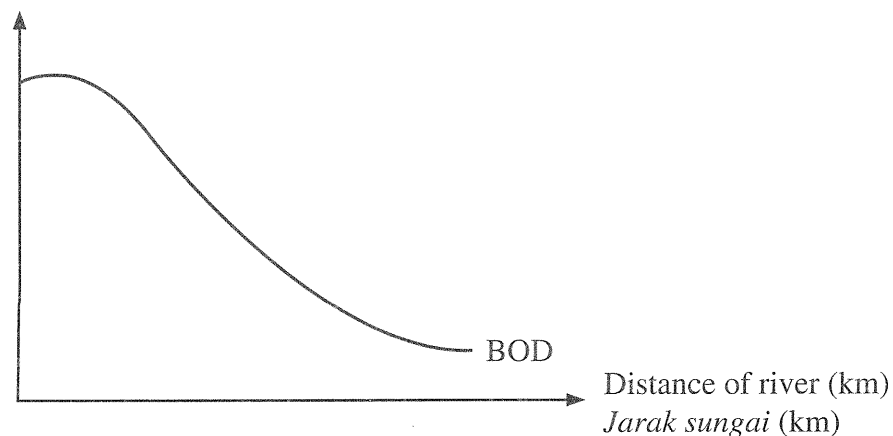

B Quantity of sewage
Kuantiti sisa kumbahan

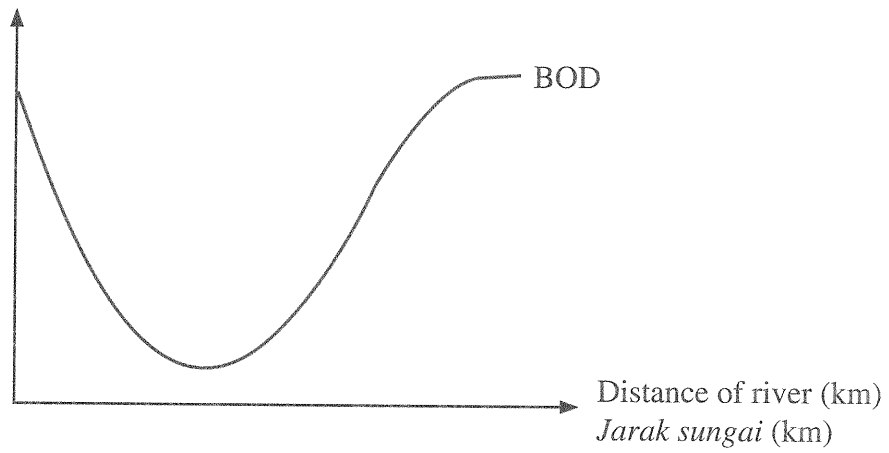

C Quantity of sewage
Kuantiti sisa kumbahan

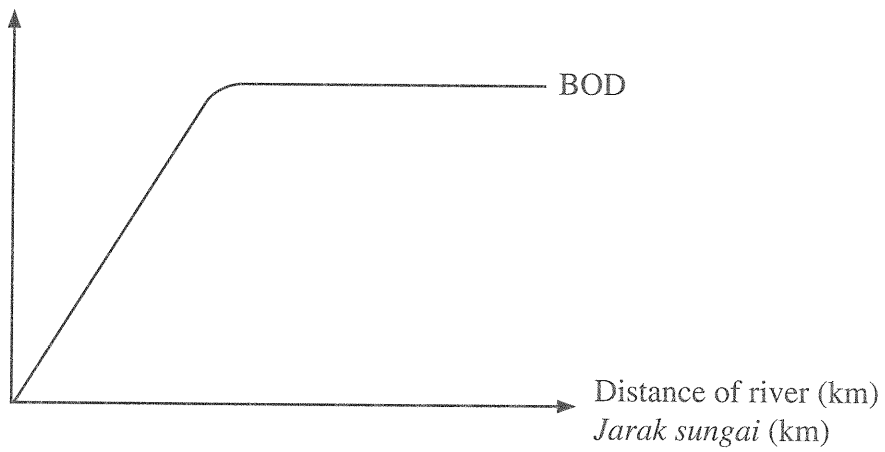

D Quantity of sewage
Kuantiti sisa kumbahan

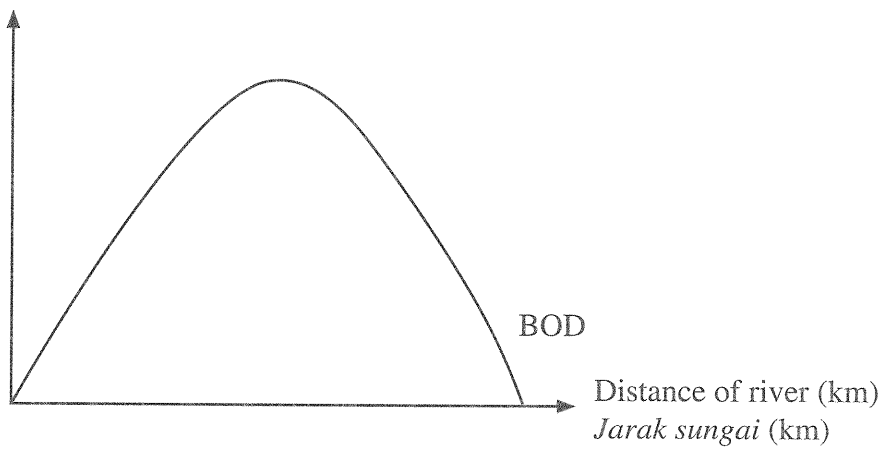

28 Which pollutant reduces the pH value of soil?

Bahan pencemar manakah yang menurunkan nilai pH tanah?

A Lead

Plumbum

B Sulphur dioxide

Sulfur dioksida

C Carbon monoxide

Karbon monoksida

D Chlorofluorocarbon

Kloroflorokarbon

29 Which of the following activities causes the greenhouse effect?

Antara aktiviti yang berikut, yang manakah menyebabkan kesan rumah hijau?

A Release of sulphur dioxide from factories

Pembebasan sulfur dioksida dari kilang

B Release of chlorofluorocarbon from aerosol

Pembebasan kloroflorokarbon daripada aerosol

C Release of carbon dioxide from the burning of forests

Pembebasan karbon dioksida daripada pembakaran hutan

D Release of carbon monoxide from motor vehicles

Pembebasan karbon monoksida daripada kenderaan bermotor

30 Diagram 19 shows two types of blood cells.
Rajah 19 menunjukkan dua jenis sel darah.

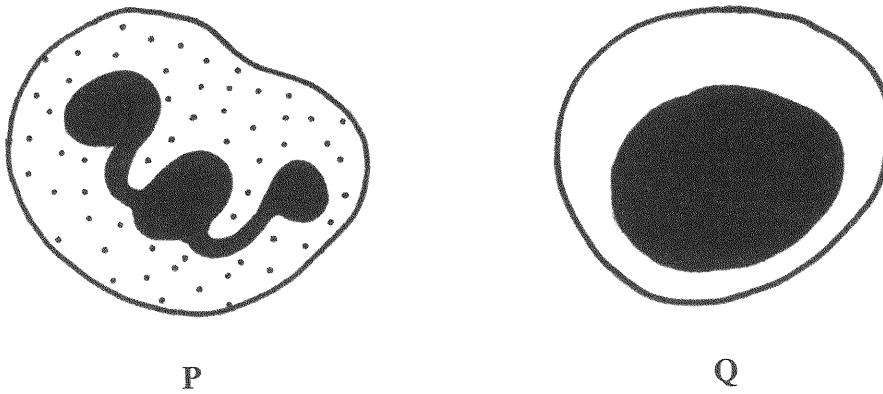

Diagram 19
Rajah 19

What are cells **P** and **Q**?
*Apakah sel **P** dan sel **Q**?*

	P	Q
A	Lymphocyte <i>Limfosit</i>	Erythrocyte <i>Eritrosit</i>
B	Eosinophil <i>Eosinofil</i>	Erythrocyte <i>Eritrosit</i>
C	Basophil <i>Basofil</i>	Neutrophil <i>Neutrofil</i>
D	Neutrophil <i>Neutrofil</i>	Lymphocyte <i>Limfosit</i>

[Lihat halaman sebelah
SULIT]

31 Diagram 20 shows the regulatory mechanism of blood pressure.

Rajah 20 menunjukkan mekanisme kawal atur tekanan darah.

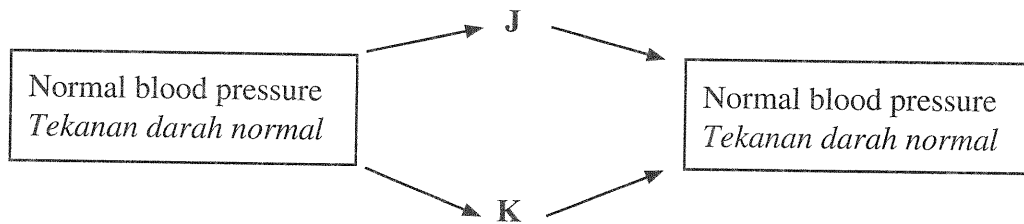

Diagram 20

Rajah 20

Which statements are correct about **J** and **K**?

Pernyataan yang manakah betul tentang **J** dan **K**?

The rate of contraction <i>Kadar pengecutan</i>		
	J	K
A	Increases at cardiac muscles of the heart and smooth muscles of the arteries <i>Meningkat pada otot kardium dalam jantung dan otot licin pada arteri</i>	Decreases at cardiac muscles of the heart and smooth muscles of the arteries <i>Menurun pada otot kardium dalam jantung dan otot licin pada arteri</i>
B	Decreases at cardiac muscles of the heart and smooth muscles of the arteries <i>Menurun pada otot kardium dalam jantung dan otot licin pada arteri</i>	Increases at cardiac muscles of the heart and smooth muscles of the arteries <i>Meningkat pada otot kardium dalam jantung dan otot licin pada arteri</i>
C	Decreases at cardiac muscles of the heart but increases at smooth muscles of the arteries <i>Menurun pada otot kardium dalam jantung tetapi meningkat pada otot licin pada arteri</i>	Increases at cardiac muscles of the heart but decreases at smooth muscles of the arteries <i>Meningkat pada otot kardium dalam jantung tetapi menurun pada otot licin pada arteri</i>
D	Increases at cardiac muscles of the heart but decreases at smooth muscles of the arteries <i>Meningkat pada otot kardium dalam jantung tetapi menurun pada otot licin pada arteri</i>	Decreases at cardiac muscles of the heart but increases at smooth muscles of the arteries <i>Menurun pada otot kardium dalam jantung tetapi meningkat pada otot licin pada arteri</i>

32 A husband and wife just had a baby. They refused the vaccination for their baby.

How would the couple be convinced to get vaccination for their baby?

Sepasang suami isteri baru sahaja menimang cahaya mata. Mereka menolak pemvaksinan terhadap bayi mereka.

Bagaimanakah pasangan tersebut dapat diyakinkan untuk mendapatkan pemvaksinan bagi bayi mereka?

I Vaccination allows baby's white blood cells to produce antibodies against certain pathogens

Pemvaksinan membolehkan sel darah putih bayi menghasilkan antibodi terhadap patogen tertentu

II Antibodies produced will remain in the baby's blood stream

Antibodi yang terhasil akan kekal di dalam aliran darah bayi

III Vaccination can protect the baby from all types of pathogen infections

Pemvaksinan dapat melindungi bayi daripada semua jenis jangkitan patogen

IV Injected vaccine contains selected antibodies to protect from pathogen infections

Vaksin yang disuntik mengandungi antibodi terpilih untuk melindungi daripada jangkitan patogen

A I and II

I dan II

B I and III

I dan III

C II and IV

II dan IV

D III and IV

III dan IV

[Lihat halaman sebelah

33 Diagram 21 shows an apparatus set-up of an experiment.

Rajah 21 menunjukkan susunan radas satu eksperimen.

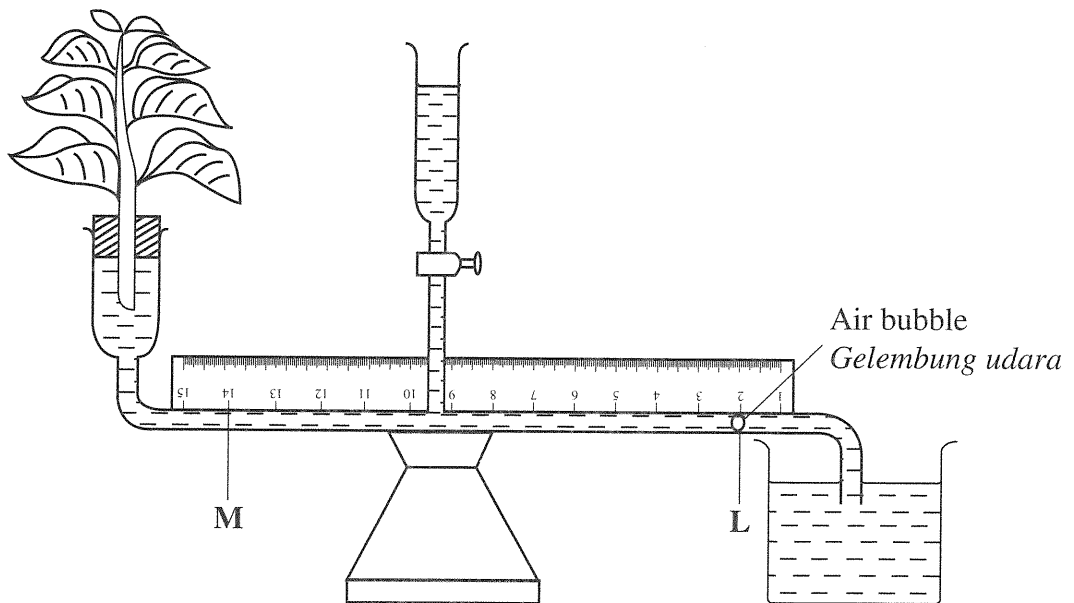

Diagram 21

Rajah 21

Which of the following factors causes the air bubble to move from **L** to **M** in the shortest period of time?

*Antara faktor berikut, yang manakah menyebabkan gelembung udara bergerak dari **L** ke **M** dalam masa yang paling singkat?*

- A** Surrounding temperature decreases
Suhu persekitaran berkurang
- B** Relative humidity increases
Kelembapan udara relatif bertambah
- C** Light intensity decreases
Keamatan cahaya berkurang
- D** Air movement increases
Pergerakan udara bertambah

- 34 The following information shows the function of a part of the human brain.
Maklumat berikut menunjukkan fungsi sebahagian daripada otak manusia.

- Control centre of body temperature
Pusat kawalan suhu badan
- Control centre to detect thirst and hunger
Pusat kawalan mengesan kehausan dan kelaparan

What is that part of the brain?

Apakah bahagian otak tersebut?

- A Cerebrum
Serebrum
- B Cerebellum
Serebelum
- C Hypothalamus
Hipotalamus
- D Medulla oblongata
Medula oblongata

[Lihat halaman sebelah
SULIT

35 Diagram 22 shows two animals.

Rajah 22 menunjukkan dua ekor haiwan.

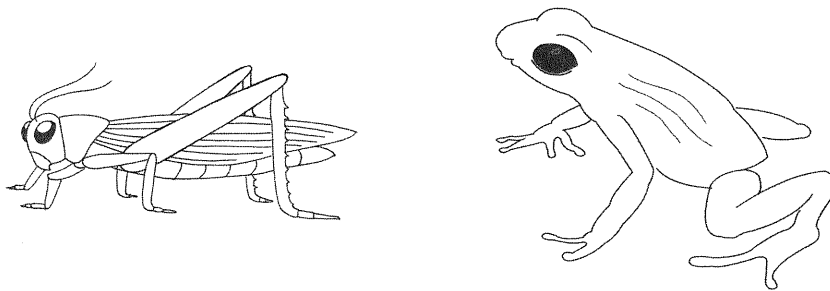

Diagram 22

Rajah 22

Which of the following statements explains the jumping movement of both animals?

Antara pernyataan berikut, yang manakah menerangkan pergerakan melompat pada kedua-dua haiwan?

- A Flexor muscles relax, extensor muscles contract and the legs are straightened
Otot fleksor mengendur, otot ekstensor mengecut dan kaki diluruskan
- B Flexor muscles contract, extensor muscles relax and legs are straightened
Otot fleksor mengecut, otot ekstensor mengendur dan kaki diluruskan
- C Flexor muscles contract, extensor muscles relax and legs are folded into a 'Z' shape
Otot fleksor mengecut, otot ekstensor mengendur dan kaki berlipat menjadi bentuk 'Z'
- D Flexor muscles relax, extensor muscles contract and legs are folded into a 'Z' shape
Otot fleksor mengendur, otot ekstensor mengecut dan kaki berlipat menjadi bentuk 'Z'

36 Diagram 23 shows a bar graph of a few impaired musculoskeletal system based on the number of patients, age and gender.

Rajah 23 menunjukkan carta palang mengenai beberapa masalah sistem otot rangka berdasarkan bilangan pesakit, umur dan jantina.

Number of patients
Bilangan pesakit

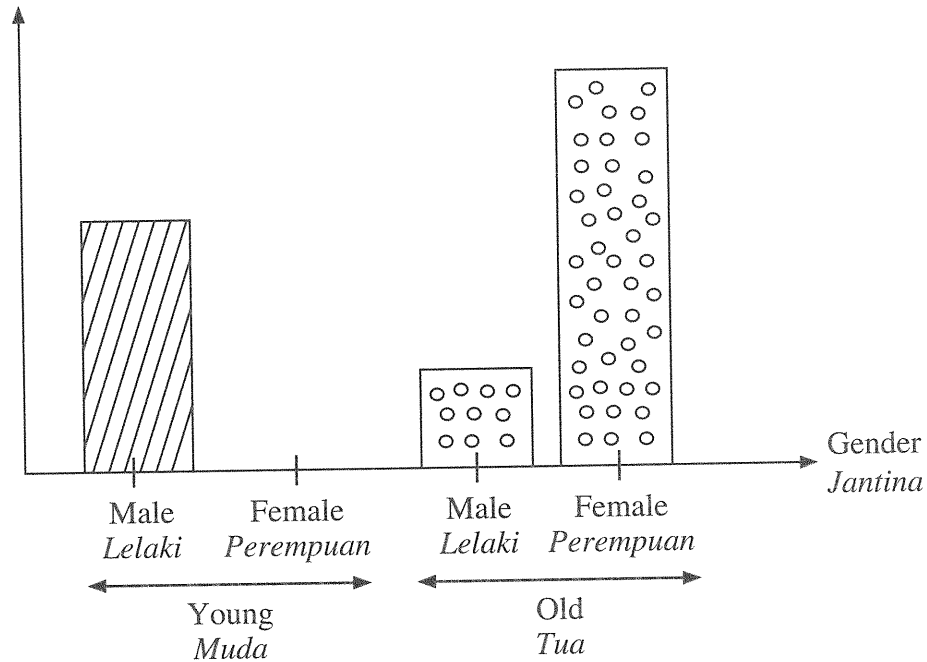







Diagram 23
Rajah 23



What are the impairment of the musculoskeletal system faced by the male and female based on the graph?

Apakah masalah sistem otot rangka yang dihadapi oleh lelaki dan perempuan berdasarkan graf?

- A**
-  Arthritis gout
Artritis gout
 -  Osteoporosis
Osteoporosis

- B**
-  Rheumatoid arthritis
Artritis reumatoid
 -  Muscular dystrophy
Distrofi otot

- C**
-  Rheumatoid arthritis
Artritis reumatoid
 -  Arthritis gout
Artritis gout

- D**
-  Muscular dystrophy
Distrofi otot
 -  Osteoporosis
Osteoporosis

[Lihat halaman sebelah
SULIT

37 Diagram 24 shows epithelial tissues found at the human taste buds.

Rajah 24 menunjukkan tisu epitelium yang terdapat pada tunas rasa lidah manusia.

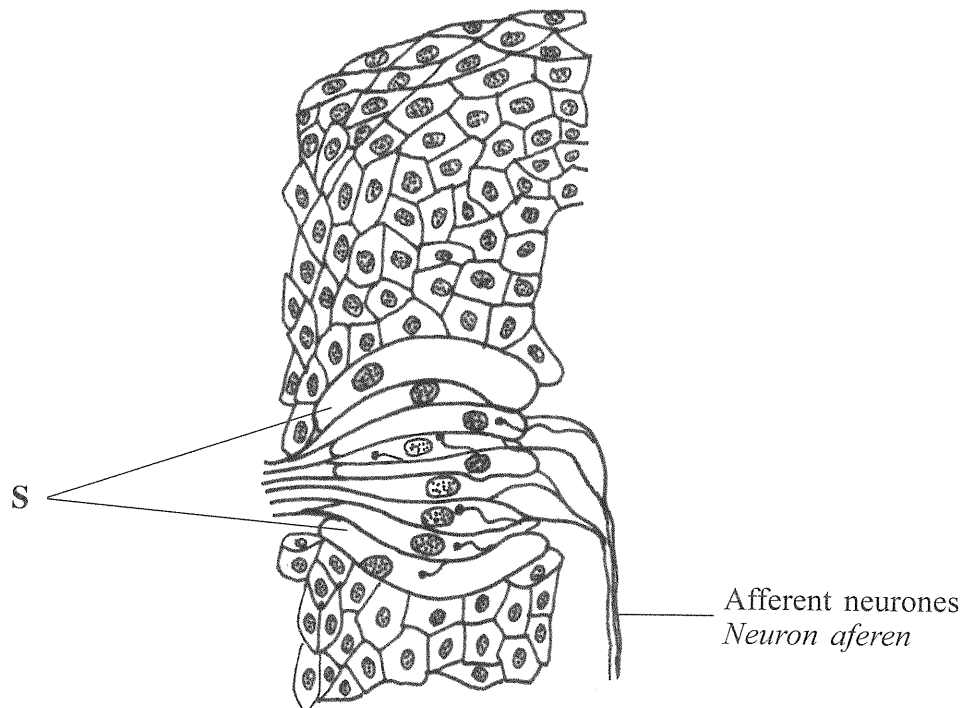

Diagram 24

Rajah 24

What is the function of S?

Apakah peranan S?

- A Detects external stimuli
Mengesan rangsangan luar
- B Sends impulses to the brain
Menghantar impuls ke otak
- C Produces responses
Menghasilkan gerak balas
- D Determines taste
Menentukan rasa

38 Diagram 25 shows the transmission of nerve impulses across the synapse.

Rajah 25 menunjukkan penghantaran impuls saraf merentasi sinaps.

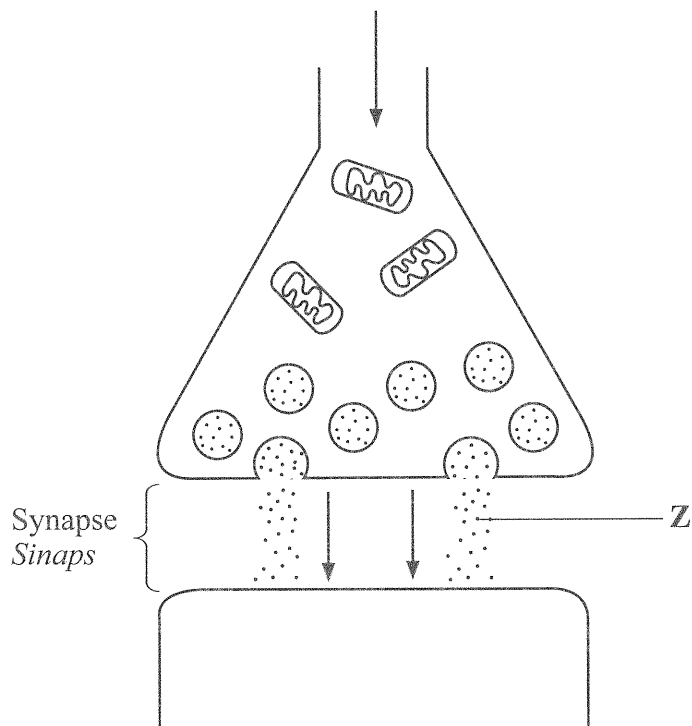

Diagram 25

Rajah 25

What is substance **Z**?

Apakah bahan **Z**?

- A Adrenaline
Adrenalina
- B Aldosterone
Aldosteron
- C Acetylcholine
Asetilkolina
- D Antidiuretic hormone
Hormon antidiuresis

[Lihat halaman sebelah
SULIT

39 Diagram 26 shows an individual who is at one area.

Rajah 26 menunjukkan seorang individu yang berada di suatu kawasan.

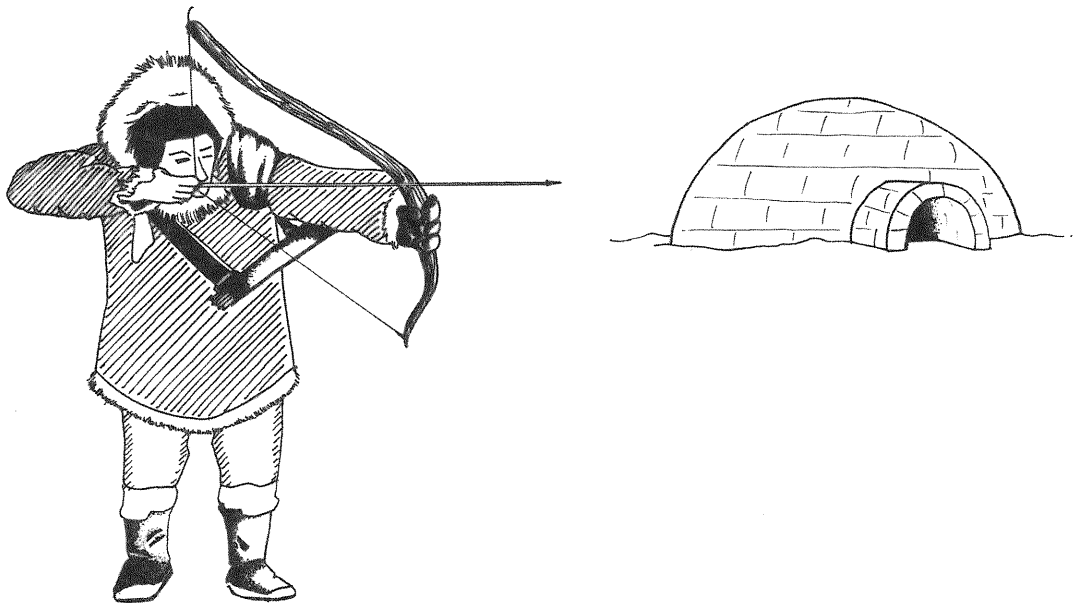

Diagram 26

Rajah 26

Which of the following explains the condition of the individual?

Antara yang berikut, yang manakah menerangkan keadaan individu tersebut?

	Activeness of the individual <i>Keaktifan individu</i>	Adrenaline secretion rate <i>Kadar rembesan adrenalina</i>	Metabolism rate <i>Kadar metabolisme</i>
A	Remain active <i>Kekal aktif</i>	Decrease <i>Menurun</i>	Decrease <i>Menurun</i>
B	Less active <i>Kurang aktif</i>	Increase <i>Meningkat</i>	Decrease <i>Menurun</i>
C	Remain active <i>Kekal aktif</i>	Increase <i>Meningkat</i>	Increase <i>Meningkat</i>
D	Less active <i>Kurang aktif</i>	Decrease <i>Menurun</i>	Increase <i>Meningkat</i>

40 What hormone is secreted by the adrenal gland?

Hormon apakah yang dirembeskan oleh kelenjar adrenal?

A Aldosterone

Aldosteron

B Thyroxine

Tiroksina

C Testosterone

Testosteron

D Antidiuretic hormone

Hormon antidiuresis

41 Diagram 27 shows a cross-section of a monocotyledon stem.

Rajah 27 menunjukkan satu keratan rentas batang monokotiledon.

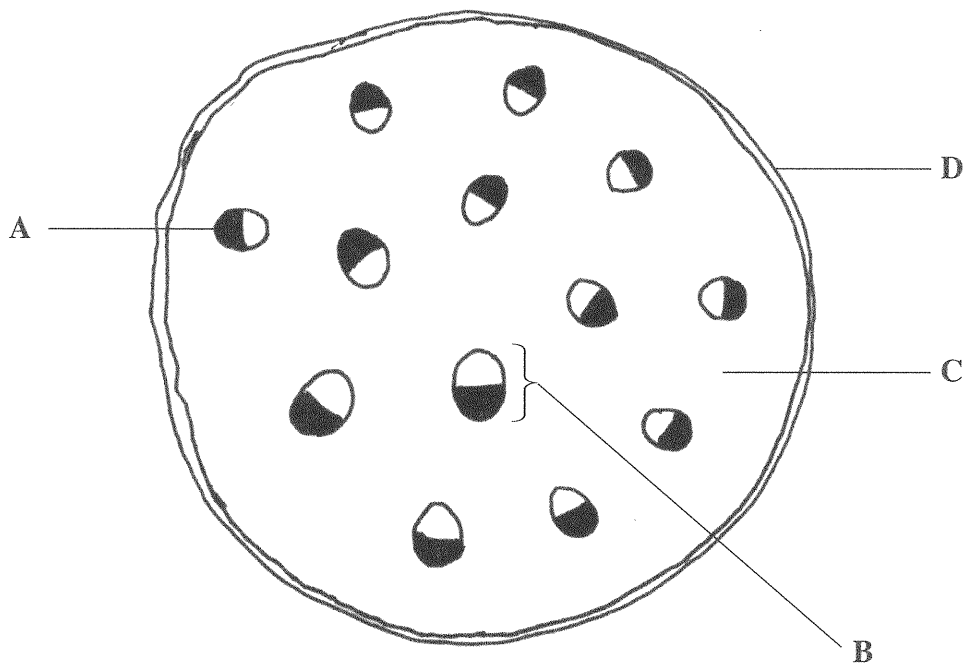

Diagram 27

Rajah 27

Which part of A, B, C or D is a vascular bundle?

Antara bahagian A, B, C dan D, yang manakah ialah berkas vaskular?

- 42 Diagram 28 shows an application known as Menstrual Period Tracker in the smartphone of a woman in the month of January 2017.

Rajah 28 menunjukkan aplikasi yang dikenali sebagai Pengesanan Tempoh Haid di dalam telefon pintar seorang wanita pada bulan Januari 2017.

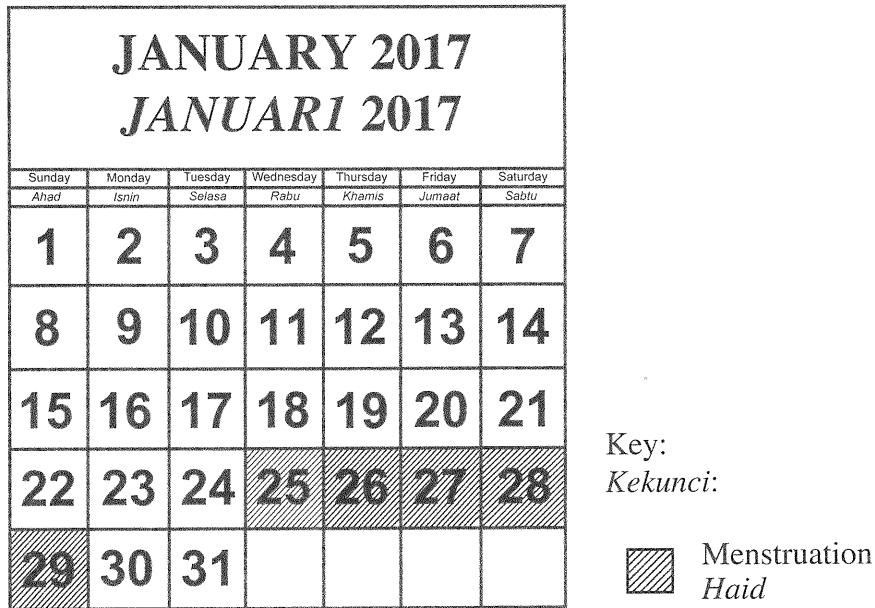

Diagram 28

Rajah 28

Which of the following statements is correct?

Antara pernyataan berikut, yang manakah betul?

- A Fertilisation is likely to occur if sperms are present in the Fallopian tube on 30th January
Persenyawaan mungkin berlaku jika sperma terdapat dalam tiub Fallopio pada 30 Januari
- B The level of progesterone decreases from 21st to 24th January
Aras progesteron berkurang dari 21 hingga 24 Januari
- C Next ovulation is likely to occur around 14th February
Pengovulan seterusnya berlaku sekitar 14 Februari
- D Oestrogen level increases from 12th to 16th January
Aras estrogen meningkat dari 12 hingga 16 Januari

43 Which hormone will stop menstrual cycle during pregnancy?

Hormon manakah yang akan menghentikan kitar haid semasa hamil?

A Oestrogen

Estrogen

B Progesterone

Progesteron

C Luteinising hormone

Hormon peluteinan

D Follicle stimulating hormone

Hormon perangsang folikel

44 Which of the following is the function of luteinising hormone?

Antara yang berikut, yang manakah fungsi hormon peluteinan?

A Stimulates ovulation

Merangsang pengovulan

B Stimulates menstrual cycle

Merangsang kitar haid

C Stimulates embryo implantation

Merangsang penempelan embrio

D Stimulates thickening of uterus wall

Merangsang penebalan dinding uterus

[Lihat halaman sebelah

45 The following information is related to hereditary.

Maklumat berikut berkaitan dengan pewarisan.

Allele for red hair, b is recessive to allele for blond hair, B. A couple of blond husband and wife has 5 children whereby 3 of them have red hair and 2 of them are blond.

Alel untuk rambut merah, b adalah resesif kepada alel rambut perang, B. Sepasang suami isteri yang berambut perang mempunyai 5 orang anak yang mana 3 daripadanya berambut merah dan 2 daripadanya berambut perang.

Which of the following explains the situation?

Antara yang berikut, yang manakah menerangkan situasi tersebut?

- I Allele B from father is combined with allele B from mother
Alel B daripada bapa berkombinasi dengan alel B daripada ibu
 - II Allele b from father is combined with allele b from mother
Alel b daripada bapa berkombinasi dengan alel b daripada ibu
 - III The ratio of the phenotypes is 1:1
Nisbah fenotip ialah 1:1
 - IV No child with heterozygous alleles is produced
Tiada anak yang mempunyai alel heterozigot dihasilkan
- A I and II
I dan II
 - B I and III
I dan III
 - C II and IV
II dan IV
 - D III and IV
III dan IV

- 46 Diagram 29 is a schematic diagram for a type of genetic disease known as haemophilia.
Rajah 29 menunjukkan rajah skema bagi sejenis penyakit genetik dikenali sebagai hemofilia.

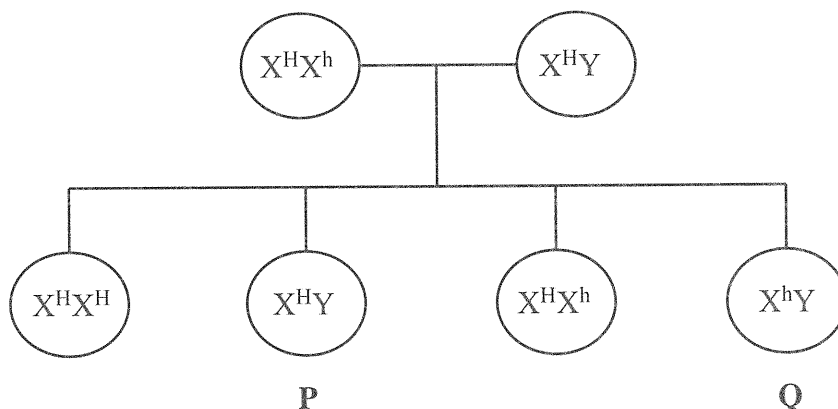

Which of the following statements are correct?

Antara pernyataan berikut, yang manakah betul?

- I **P** is a carrier
P ialah pembawa
 - II All the sons are haemophiliac
Semua anak lelaki menghidap hemofilia
 - III **Q** has haemophilia
Q menghidap hemofilia
 - IV All the daughters are normal
Semua anak perempuan adalah normal
- A I and II
I dan II
 - B I and III
I dan III
 - C II and IV
II dan IV
 - D III and IV
III dan IV

[Lihat halaman sebelah
SULIT

47 Diagram 30 shows a stage in the process of meiosis.

Rajah 30 menunjukkan satu peringkat dalam proses meiosis.

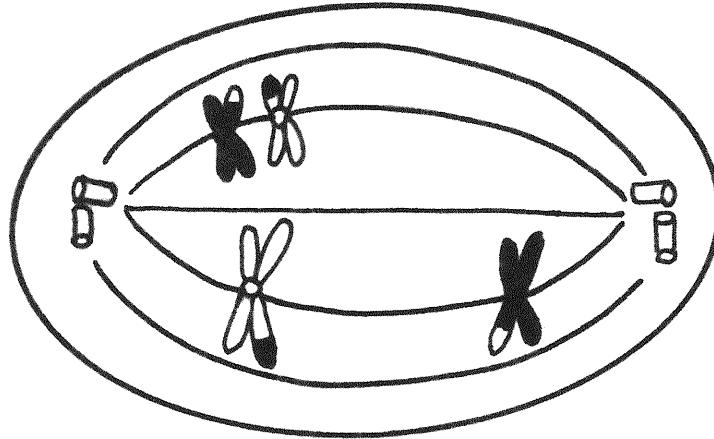

Diagram 30

Rajah 30

Which of the following diseases can be related to the condition that occurs during the stage?

Antara penyakit berikut, yang manakah boleh dikaitkan dengan keadaan yang berlaku semasa peringkat itu?

- A Albinism
Albinisme
- B Thalassaemia
Talasemia
- C Turner's syndrome
Sindrom Turner
- D Haemophilia
Hemofilia

48 A hereditary disease can be inherited either caused by a sex-linked gene or a defected gene.

Which of the following examples are correct for hereditary diseases caused by defected genes?

Penyakit pewarisan boleh diwarisi sama ada disebabkan oleh gen terangkai seks atau gen yang cacat.

Antara contoh berikut, yang manakah betul bagi penyakit pewarisan yang disebabkan oleh gen yang cacat?

I Down's syndrome

Sindrom Down

II Turner's syndrome

Sindrom Turner

III Thalassaemia

Talasemia

IV Albinism

Albinisme

A I and II

I dan II

B I and III

I dan III

C II and IV

II dan IV

D III and IV

III dan IV

[Lihat halaman sebelah

SULIT

49 Table 2 shows a variation of a group of students.

Jadual 2 menunjukkan variasi bagi sekumpulan murid.

Characteristic <i>Ciri</i>	Presence of dimples <i>Kehadiran lesung pipit</i>	
	Present <i>Ada</i>	Absent <i>Tiada</i>
Trait <i>Trait</i>		
Number of students <i>Bilangan murid</i>	20	5

Table 2

Jadual 2

Which of the following is correct about the trait?

Antara yang berikut, yang manakah betul mengenai trait itu?

- A A dominant trait
Merupakan trait dominan
- B A recessive trait
Merupakan trait resesif
- C Form a normal distribution graph
Membentuk graf taburan normal
- D Can be measured quantitatively
Boleh diukur secara kuantitatif

50 Diagram 31 shows two red blood cells.

Rajah 31 menunjukkan dua sel darah merah.

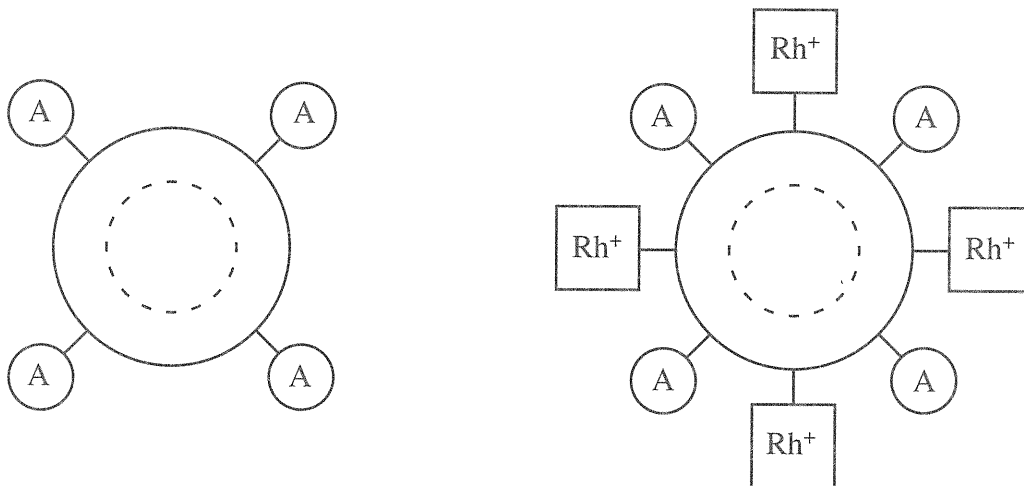

Diagram 31

Rajah 31

What is the type of variation shown in Diagram 31 and what factor causes it?

Apakah jenis variasi yang ditunjukkan dalam Rajah 31 dan apakah faktor yang menyebabkannya?

	Type of variation <i>Jenis variasi</i>	Factor <i>Faktor</i>
A	Continuous <i>Selanjara</i>	Genetic only <i>Genetik sahaja</i>
B	Continuous <i>Selanjara</i>	Genetic and environment <i>Genetik dan persekitaran</i>
C	Discontinuous <i>Tidak selanjara</i>	Genetic only <i>Genetik sahaja</i>
D	Discontinuous <i>Tidak selanjara</i>	Genetic and environment <i>Genetik dan persekitaran</i>

END OF QUESTION PAPER
KERTAS PEPERIKSAAN TAMAT

INFORMATION FOR CANDIDATES
MAKLUMAT UNTUK CALON

1. This question paper consists of **50** questions.
Kertas peperiksaan ini mengandungi 50 soalan.
2. Answer **all** questions.
Jawab semua soalan.
3. Each question is followed by four alternative answers **A, B, C** or **D**. For each question, choose **one** answer only. Blacken your answer on the objective answer sheet provided.
Setiap soalan diikuti oleh empat pilihan jawapan iaitu A, B, C dan D. Bagi setiap soalan, pilih satu jawapan sahaja. Hitamkan jawapan kamu pada kertas jawapan objektif yang disediakan.
4. If you wish to change your answer, erase the blackened mark that you have made. Then blacken the new answer.
Sekiranya anda hendak menukar jawapan, padamkan tanda yang telah dibuat. Kemudian hitamkan jawapan yang baharu.
5. The diagrams in the questions provided are not drawn to scale unless stated.
Rajah yang mengiringi soalan tidak dilukis mengikut skala kecuali dinyatakan.
6. You may use a scientific calculator.
Anda dibenarkan menggunakan kalkulator saintifik.